

**GROUP 300
COMPLEMENTS
MOD. 242A/133**



**DAVINCI
VALVES™**

**TECHNICAL
DATA SHEET
WATER Series**

SURFACE STREET BOX

**DAVINCI
VALVES™**



**QUALITY
ASSUREMENT**

**DAVINCI
VALVES™**



**PRODUCT QT
ASSUREMENT**

**DAVINCI
VALVES™**



**COMPANY QT
ASSUREMENT**

www.davincivalves.com

18 Dongyu Street, Square One,
11th Floor 1101, Jinjiang District,
Chengdu, Sichuan CHINA

10F/Tower A, Billion Center,
1 Wang Kwong Road, Kowloon Bay
Kowloon HONG KONG

SURFACE STREET BOX

Ref.242A.133

MATERIALS:

Body and cover in Grey Iron GJL250 with bituminous varnish or coating

STANDARDS:

Easy levelling during the resurfacing operations of streets thanks to the use of a specific extension

Optional chain making the cover integral with the body

All circulated carriageways of streets requiring the access to a buried gate valve

Wide bearing surface facilitating the bedding and reducing the risk of subsidence under traffic

Specific design preventing the lid from being removed by street cleaning equipment

Weight 4.5kg

FIELD OF APPLICATION:

Product not subjected to standard EN 124-2.

All circulated carriageways of streets requiring the access to a buried gate valve.

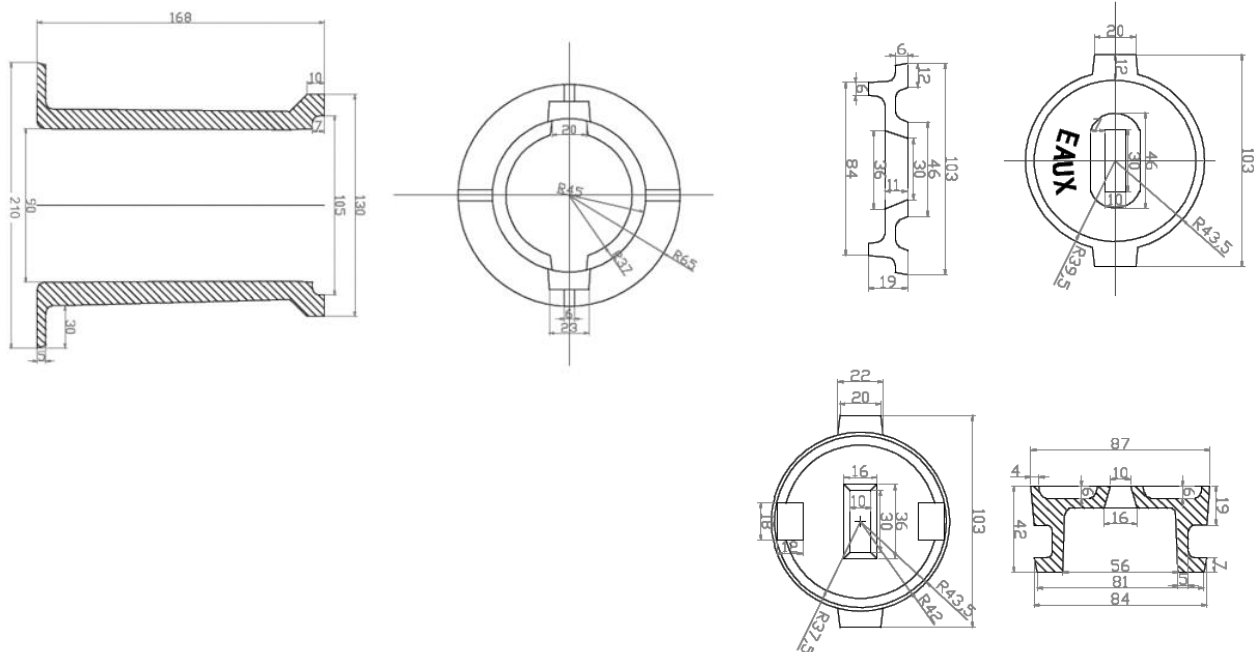

All the components can be substituted with equivalent or higher-class materials.

DAVINCI VALVES LTD, is constantly looking at all ways of improving our products and services related to the water, fire and industry sector and therefore we reserve the right to change, without prior notice, any of the data contained here. Please contact our Technical Sales Department for detailed advice.
© 2018 DAVINCI VALVES LTD.

"For professionals who wants more"



DAVINCI
VALVES™

www.davincivalves.com