

**GROUP 200  
GATE VALVES  
MOD.  
200A/09.2**



**DAVINCI  
VALVES™**

# TECHNICAL DATA SHEET

## WATER Series

**RESILIENT SEAT GATE VALVE BS5153 NON  
RISING STEM FLANGED END ANSI16.10**

**DAVINCI  
VALVES™**



**QUALITY  
ASSUREMENT**

**DAVINCI  
VALVES™**



**PRODUCT QT  
ASSUREMENT**

**DAVINCI  
VALVES™**



**COMPANY QT  
ASSUREMENT**

[www.davincivalves.com](http://www.davincivalves.com)

18 Dongyu Street, Square One,  
11th Floor 1101, Jinjiang District,  
Chengdu, Sichuan CHINA

10F/Tower A, Billion Center,  
1 Wang Kwong Road, Kowloon Bay  
Kowloon HONG KONG

## RESILIENT SEAT GATE VALVE NON-RISING STEM BS5163 Ref.200A / 150 PSI

### APPLICATION:

Potable water distribution and pumping,  
sewage, irrigation

### STANDARDS:

Design: BS5163.

Manufacture according to: EN 1074-2./GB/T12232-1989

Face to Face: ANSI B16.10 EN-558-1 SERIE 3

Mounting between flanges: ANSI150 EN 1092-2, ISO 7005-2.

Pressure Test: EN 12266-1 Rate A. GB/T13927-1992

EU directive 2014/68/EU: Products excluded, article 1, § 2b up to ND300. Risk Category I MoD. A from ND350 to ND600

EPDM according to UNE -EN 681-1:1996

PTFE according to UNE-EN 13000-1:2006

### GENERAL CHARACTERISTICS:

Range from ND40 up to ND1200.

Complies according the norm EN 1074-2

Full bore.

100% Tightness in both ways.

Minimum head loss.

Repackable under pipeline pressure.

Low torque values.

Epoxy paint 250 microns: RAL 5015.

### WORKING CONDITIONS:

Pressure Ratings: 150psi

Working Temperature: -10C +80C

Suitable Media: Water

Consult Factory for other applications

Nº	ITEM	MATERIAL
1	BODY	QT500-7
2	GATE	QT500-7/EPDM
3	NUT	ZCuZn38
4	SHAFT	2Cr13
5	BODY-BONNET GASKET	EPDM
6	BONNET	QT500-7
7	ORING	EPDM
8	PACKING	PTFE
9	O-RINGS	EPDM
10	SHAFT-NET O-RINGS	NBR
11	O-RINGS	EPDM
12	DUST COVER	NBR
13	GLAND NUT	HPb59-1
14	BOLTS	A2
15	DUST PROTECTOR	NBR

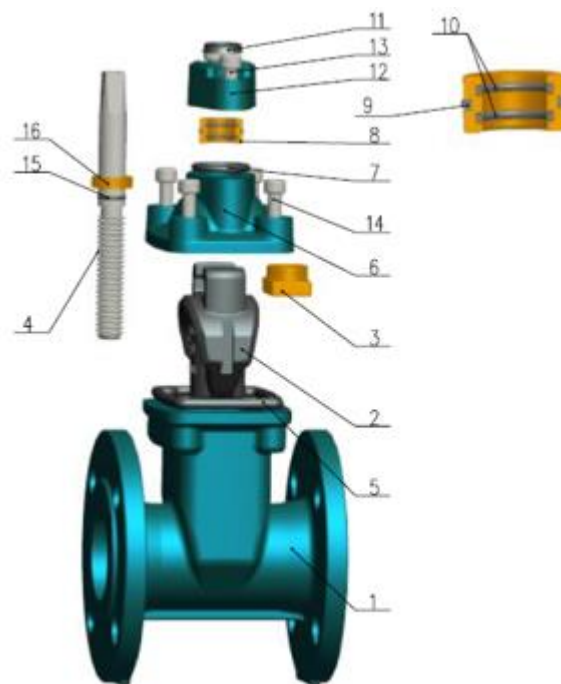

*All the components can be substituted with equivalent or higher-class materials.*

DAVINCI VALVES LTD, is constantly looking at all ways of improving our products and services related to the water, fire and industry sector and therefore we reserve the right to change, without prior notice, any of the data contained here. Please contact our Technical Sales Department for detailed advice.

© 2018 DAVINCI VALVES LTD.

www.davincivalves.com info@davincivalves.com +34 616553797 / +86 17340168233  
18 Dongyu Street, Square One 11th Floor 1101. Jinjiang District, Chengdu, Sichuan Province, China

## RESILIENT SEAT GATE VALVE NON-RISING STEM BS5163 Ref.200A / 150 PSI

ND	L	H	Torque (N.m)	Weight KG
50	178	240	50	9,6
65	190	280	60	10,6
80	203	305	60	13,4
100	229	340	80	18,18
125	254	390	100	28,4
150	267	445	120	32,15
200	292	545	150	57,1
250	330	635	200	79
300	356	730	250	110,8
350	381	760	300	158,4
400	406	840	350	208
500	457	1005	450	365
600	508	1150	550	586

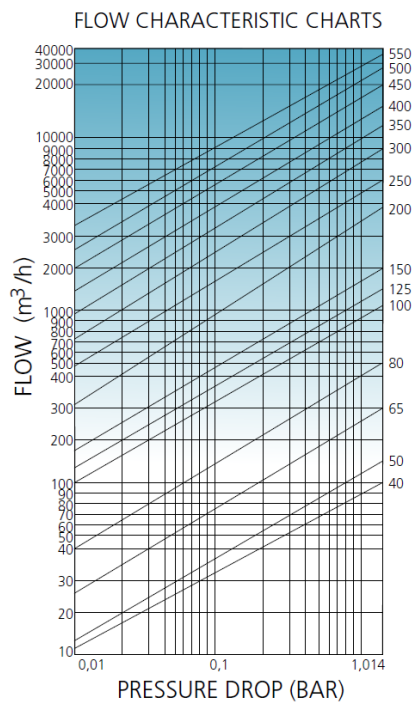
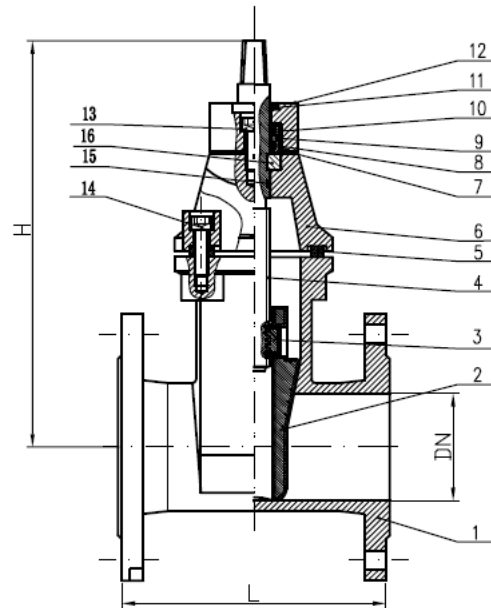

All the components can be substituted with equivalent or higher-class materials.

DAVINCI VALVES LTD, is constantly looking at all ways of improving our products and services related to the water, fire and industry sector and therefore we reserve the right to change, without prior notice, any of the data contained here. Please contact our Technical Sales Department for detailed advice.

© 2018 DAVINCI VALVES LTD.  
www.davincivalves.com info@davincivalves.com +34 616553797 / +86 17340168233  
18 Dongyu Street, Square One 11th Floor 1101. Jinjiang District, Chengdu, Sichuan Province, China

*"For professionals who wants more"*

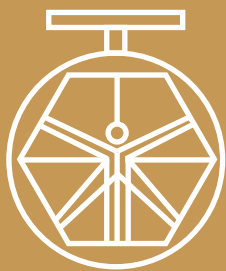

DAVINCI  
VALVES™