

**GROUP 500  
AUTOMATIC  
CONTROL  
VALVES MOD.  
505A/102**

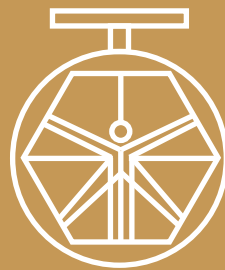

**DAVINCI  
VALVES™**

**TECHNICAL  
DATA SHEET  
WATER Series**

**AIR RELIEF VALVES SEWAGE WATER  
FLANGED END TRIPLE FUNCTION**

**DAVINCI  
VALVES™**



**QUALITY  
ASSUREMENT**

**DAVINCI  
VALVES™**



**PRODUCT QT  
ASSUREMENT**

**DAVINCI  
VALVES™**



**COMPANY QT  
ASSUREMENT**

[www.davincivalves.com](http://www.davincivalves.com)

18 Dongyu Street, Square One,  
11th Floor 1101, Jinjiang District,  
Chengdu, Sichuan CHINA

10F/Tower A, Billion Center,  
1 Wang Kwong Road, Kowloon Bay  
Kowloon HONG KONG

## AIR RELIEF FOR SEWAGE WATER TRIPLE FUNCTION

Ref.500A / PN 10-16-ANSI150#

### STANDARDS:

Hydrostatic test according to EN 12266-1, class A.  
EC directive  
Construction according to EN 1074-4 and AWWA  
C512  
Flanged according to ISO 7005-2

### TECHNICAL INFORMATION:

Design acc. To: AWWA C512/EN1074-4/CJ-T 217-  
2005  
Thread: BSP / ISO228-1  
Testing acc. To: EN1074-1 & 4 /EN12266  
Working Pressure: PN10/16, CLASS 125/150

### CHARACTERS:

Small Orifice 2mm diameter for high-speed venting  
Full stainless-steel suits for sewerage liquid  
Triple function  
\*\*Special specification available upon request

### SPECIAL ADVANTAGED:

100% -full flow area thru the valve internal.  
The float can resist high pressure from 51-70Bar for  
different size air valve.  
Blow shut pressure can come up to 2.0Bar. Generally,  
up to 0.5Bar is enough for operation.  
Single body preventing breakage of dual bodies  
connection.  
All internal parts are 304SS material without rusting.  
Full flow area- enough for air exhausting  
Min. closing pressure can be 0.3Bar, and 0.2Bar can  
be provided upon request.



*All the components can be substituted with equivalent or higher-class materials.*

DAVINCI VALVES LTD, is constantly looking at all ways of improving our products and services related to the water, fire and industry sector and therefore we reserve the right to change, without prior notice, any of the data contained here. Please contact our Technical Sales Department for detailed advice.  
© 2018 DAVINCI VALVES LTD.

[www.davincivalves.com](http://www.davincivalves.com) [www.davincivalves.en.alibaba.com](http://www.davincivalves.en.alibaba.com) [info@davincivalves.com](mailto:info@davincivalves.com) +34 616553797 / +86 17340168233  
18 Dongyu Street, Square One 11th Floor 1101. Jinjiang District, Chengdu, Sichuan Province, China

## AIR RELIEF FOR SEWAGE WATER TRIPLE FUNCTION

Ref.500A / PN 10-16-ANSI150#

Nº	ITEM	MATERIAL
1	BODY	SS316/SS304
2	FLOAT	SS316/SS304
3	KINETIC BAR	SS316/SS304
4	TOP FLANGE	CF8M/CF8/UHMW
5	GASKET	NBR/VITON
6	SEALING SEAT	EPDM/NBR
7	UP VENT FLOAT	UHMW
8	UP VALVE BODY	ABS

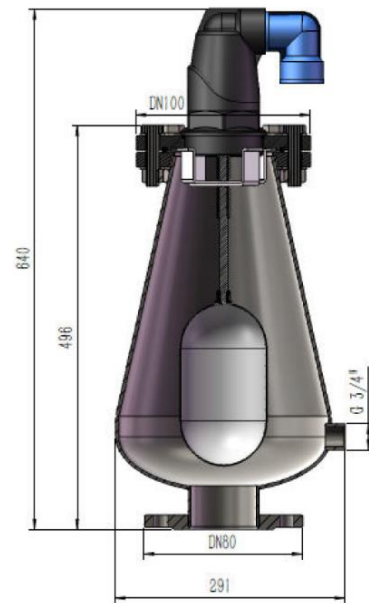

VALVE SIZE		2" (DN50)	3" (DN80)	4" (DN100)	6" (DN150)
H overall height	mm	640	640	640	640
W overall width	mm	291	291	291	291
A vent orifice area	square mm	12.56	12.56	12.56	12.56
K big orifice area	square mm	855	855	855	855
E drain diameter	BSP	1-1/2"	1-1/2"	1-1/2"	1-1/2"

All the components can be substituted with equivalent or higher-class materials.

DAVINCI VALVES LTD, is constantly looking at all ways of improving our products and services related to the water, fire and industry sector and therefore we reserve the right to change, without prior notice, any of the data contained here. Please contact our Technical Sales Department for detailed advice.  
© 2018 DAVINCI VALVES LTD.

[www.davincivalves.com](http://www.davincivalves.com) [www.davincivalves.en.alibaba.com](http://www.davincivalves.en.alibaba.com) [info@davincivalves.com](mailto:info@davincivalves.com) +34 616553797 / +86 17340168233  
18 Dongyu Street, Square One 11th Floor 1101. Jinjiang District, Chengdu, Sichuan Province, China

*"For professionals who wants more"*

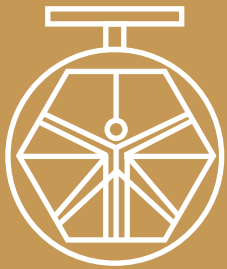

DAVINCI  
VALVES™